

## GRINDER PUMP

### ▶ Application

- In the APMC market processing waste and chop vegetable garbage.
- In textile plants to process waste cotton fiber pigment slurry and wool fiber waste slurry.
- In ETP and STP plants transfer waste while chopping solid soft particles.

### ▶ Features

- Maximum Capacity : 950 LPM
- Maximum Head : 32 Mtr.
- Impeller type : vortex
- Solids (soft) : 40 mm
- Maximum Temp : 70° C
- Highly operational reliability.
- It prevents clogging with some troublesome objects such as sanitary napkins, plastic, rubber, disposable, diapers and cloth items.

## DSPC MODEL



### ▶ Technical Specification

#### MOTOR

- Supply : 3 PH, AC - 50/60Hz, 380 - 440 volt.  
1PH AC, 50 Hz, 210 - 240 V
- Rated speed : 2800 RPM
- Power rating : 1.12 KW - 11.2 KW
- Two Pole induction continuously rated motors with Squirrel cage rotor and stator insulation F Class.

#### POWER CABLE

- Waterproof / Oil Proof PVC insulated double-sheathed copper conductor flexible cable.

#### SHAFT SEAL

- Mechanical seal : Silicon vs Silicon in Motor

#### MATERIAL OF CONSTRUCTION

- Pumps casting : Gr. Casting F
- Impeller : SS 410 Harden
- Cutter with blade : SS 410 Harden
- Rotor shaft : SS 410
- Rubber part : Nitrile SHOR - A75 (+/- 5%)

## Performance Curve

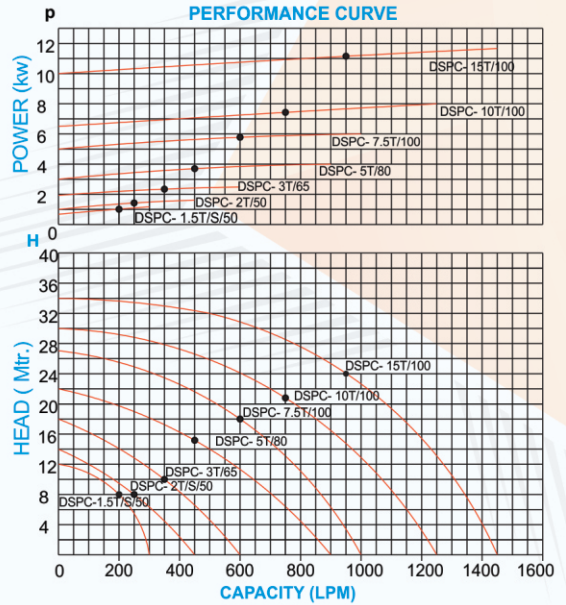
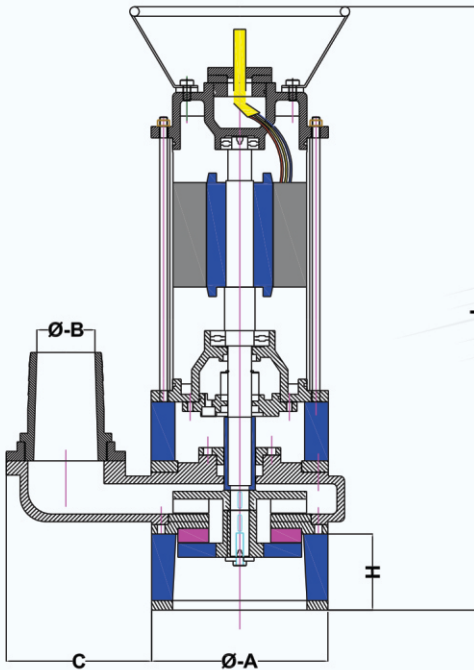

## Product Range

PUMP TYPE	MOTOR 3Ø PHASE		DELI. SIZE	WEIGHT (APPX.) (W/O CABLE)	DISCHARGE IN LPM							Overall Dimension					
					200	250	350	450	600	750	950						
TYPE	H.P	K.W	MM.	KG.	Working Range							L	C	ØA	ØB	H	
					HEAD IN METER												
DSPC 1.5H 50 1Ph/3Ph	1.50	1.12	50mm.	35 Kg	08	06	-	-	-	-	-	-	530	100	185	50	70
DSPC 2H 50 1Ph/3Ph	2.00	1.50	50mm.	43 Kg	10	08	04	00	-	-	-	-	470	125	240	50	70
DSPC 3H 65 3PH	3.00	2.25	75mm.	50 Kg	14	13	10	07	00	-	-	-	470	125	240	65	70
DSPC 5H 80 3Ph	5.00	3.75	100mm.	77 Kg	20	19	17	15	12	06	-	-	570	160	270	80	65
DSPC 7.5 100 3Ph	7.50	5.75	100mm.	83 Kg	25	24	23	22	18	13	04	-	600	160	270	100	65
DSPC 10H 100 3Ph	10.0	7.50	100mm.	95 Kg	29	28	27	26	24	21	15	-	630	160	270	100	65
DSPC 15H 100 3Ph	15.0	11.25	100mm.	100 Kg	34	34	33	32	31	28	24	-	650	160	270	100	65

\* Due to continuous product research & development specification may be change without any notice

## Prakash Pumps

J-29/30, 1st Phase, J type Area, GIDC,  
Vapi - 396195, Gujarat, India.  
info@figpumps.com

+91 26029 64267 | +91 94093 01772



Scan QR-Code  
To Visit Website